



Hydraulic Spreader Instruction Manual

MODEL: HFSS14

SFA Companies 10939 N. Pomona Ave. Kansas City, MO 64153
Tel: 888-332-6419 * Fax: 816-448-2142
E-mail: sales@bvahydraulics.com Website: www.bvahydraulics.com



This is the safety alert symbol. It is used to alert you to potential personal injury hazards. Obey all safety messages that follow this symbol to avoid possible injury or death.

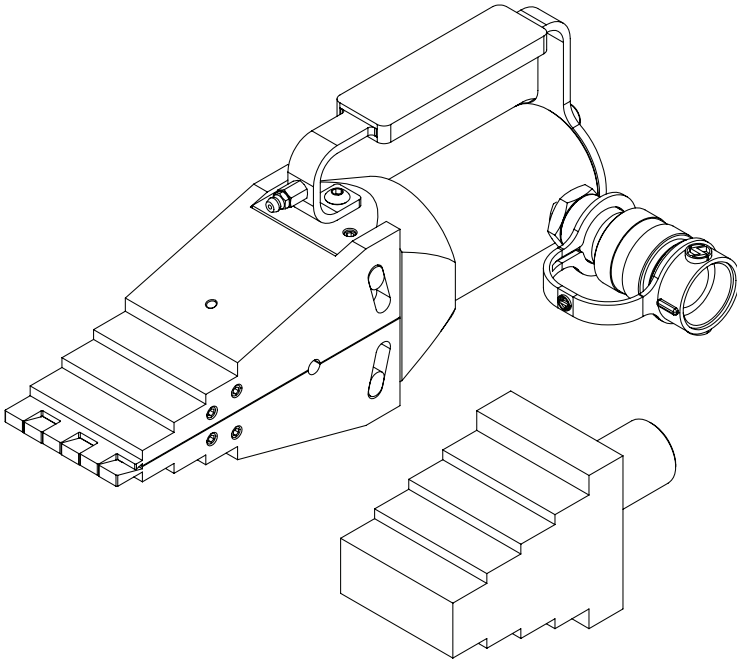

This is the safety alert symbol. It is used to alert you to potential personal injury hazards. Obey all safety messages that follow this symbol to avoid possible injury or death.

⚠ WARNING: Cancer and Reproductive Harm.
www.P65Warnings.ca.gov

Save these instructions. For your safety, read and understand the information contained within. The owner and operator shall have an understanding of this product and safe operating procedures before attempting to use this product. Make certain that the operator thoroughly understands the inherent dangers associated with the use and misuse of the product. If any doubt exists as to the safe and proper use of this product as outlined in this factory authorized manual, remove from service immediately.

Inspect before each use. Do not use if broken, bent, cracked or otherwise damaged parts are noted. If any component of this product has been or suspected to have been subjected to a shock load (a load dropped suddenly, unexpectedly upon it), discontinue use until checked out by a BVA Hydraulics authorized service center. Owners and operators of this equipment shall be aware that the use and subsequent repair of this equipment may require special training and knowledge. It is recommended that an annual inspection be done by qualified personnel and that any missing or damaged parts, decals, warning / safety labels or signs be replaced with factory authorized replacement parts only. Any spreader that appears to be damaged in any way, is worn or operates abnormally shall be removed from service immediately until such time as it can be repaired/replaced. Instruction Manuals are available from manufacturer.

PRODUCT DESCRIPTION

BVA Hydraulic Spreaders are designed for rated capacity pushing and spreading. A wide variety of applications exist for this category of product.

Special skill, knowledge and training may be required for a specific task and the product may not be suitable for all the jobs described above. Unsuitable applications would include applications that call for a device to move, level or support persons, animals, hazardous materials, mobile homes/dwellings in general, mirrors and/or plate glass, and/or to connect/secure hatches, components, etc. between bulkheads. The user ultimately must make the decision regarding suitability of the product for any given task and therefore accept responsibility for that decision. **Immediately** after lifting, loads must be supported by appropriate mechanical means.

⚠ NEVER rely upon a hydraulic spreader as a support device! **Immediately** after lifting, loads must be supported by appropriate mechanical means.

⚠ Always check connections before using. Alteration of these products is strictly prohibited. Use only those adapters and attachments provided and approved by the manufacturer.

⚠ To reduce the risk of personal injury and/or property damage, ensure that the rated working pressure of each pressurized attachment be equal to or greater than the rated working pressure developed by the hydraulic pump.

BEFORE USE

1. Before using this product, read the owner's manual completely and familiarize yourself thoroughly with the product, its components and recognize the hazards associated with its use.
2. Verify that the product and the application are compatible. If in doubt, call BVA Hydraulics Technical Service (888) 332-6419.
3. Inspect before each use. Do not use if bent, broken, leaking or damaged components are noted.
4. Replace worn or damaged parts and assemblies with BVA Hydraulics authorized replacement parts only. Lubricate as instructed in Maintenance Section.
5. Use ANSI compliant eye protection when operating or near this equipment.
6. Ensure method of confirming load is accurate and working properly. Have gauge or load cell accuracy verified by qualified personnel on a yearly basis.
7. Spreaders should be stored where protected from the elements, abrasive dust, and damage. These devices may be stored in virtually any position.

GENERAL SAFETY INFORMATION

1. Ensure that **both** spreader jaws fully engage the load and that the load is centered on the serrated portion of each spreader jaw before pressurizing spreader. Do not load off center.
2. Always monitor the hydraulic pressure developed in the spreader ram by using an inline pressure gauge. These spreaders are designed to develop 10,000 psi at rated capacity.

⚠ If bowing or bending of the spreader jaws occurs, **STOP, immediately release pressure!** Evaluate the set-up and consider a higher capacity system. Bowing or bending of components indicates that the spreader is overloaded.

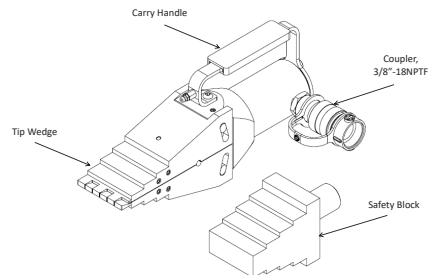

Figure 1: Major Components of HFSS14

SPECIFICATIONS

Model No.	Spreader Capacity (Ton)	Cylinder Effective (Sq. In.)	Oil Capacity (Cu. In.)	Tip Clearance (In.)	Spread Range (In.)		Overall Length (In.)	Weight (Lbs.)
					Front Tip	Rear Tip		
HFSS14	14 Ton	2.24	4.48	0.24	0.24 - 1.22	1.42 - 2.4	11.8	22.2

!WARNING



Failure to comply with the following warnings may result in **personal injury** as well as **property damage**.



- Study, understand, and follow all instructions provided with and on this device before use.
- The user must be a qualified operator familiar with the correct operation, maintenance, and use of cylinders.



Wear protective gear when operating hydraulic equipment.



This device is **NOT** suitable for use as **support** device! As the load is lifted, use blocking and cribbing to guard against a falling load. Stay clear of a lifted load before it is properly supported. Never rely on hydraulic pressure to support a load.



Crush Hazard. Keep hands and feet away from cylinder and workpiece during operation.



- Do not exceed rated capacity of the cylinder or any equipment in the system. The cylinder is designed for a max. pressure of 10,000 psi.
- Do not connect a cylinder to a pump with

higher pressure rating.

- Do not subject cylinder to a shock loads, a load dropped suddenly, causing the system pressure to exceed rated pressure.



The system operating pressure must not exceed the pressure rating of the lowest rated component the system. Install a pressure gauge or other load measuring instrument to monitor the operating pressure. Burst hazard exists if hose, connection or any other component in the system exceed its rated pressure.



Avoid damaging hydraulic hose. Do not allow hose to kink, twist, curl, crush, cut or bend so tightly that fluid flow within the hose is blocked or reduced. Periodically inspect the hose for wear.



Do not pull, position or move cylinder setup by the hose. Use carrying handle or other means of safe transport.



Do not handle pressurized hoses. Never attempt to grasp a leaking pressurized hose. Ensure to release the system pressure before disconnecting hydraulic hose or connections.



Hydraulic fluid can ignite and burn. Keep hydraulic equipment away from flames and heat. Excessive heat will soften seals, resulting in fluid leaks. Heat also weakens hose materials.



Cylinder must be on a stable base which is able to support the load while pushing or lifting. Use shims, friction material or constrains to prevent slippage of the base or load. Ensure cylinder is fully engaged into/onto adapters, extension accessories.



Center load on cylinder. Distribute load evenly across the entire saddle surface. Do not off-center loads on a cylinder. The load can tip or the cylinder can "kick out".



Never try to disassemble a hydraulic cylinder, refer repairs to qualified, authorized personal. Contact BVA Hydraulics tech service for authorized service center.



Do not subject hose to sharp objects or heavy impact.



Hose material or seals must not come in contact with corrosive materials such as battery acid, creosote-impregnated objects and wet paint. Never paint a coupler or hose.



- No alteration shall be made to the cylinder.
- Use only factory authorized fasteners, accessories and hydraulic fluid.

OPERATION

⚠ ALWAYS monitor pressure, load or position using suitable equipment. Pressure may be monitored by means of an optional manifold and gauge. Load may be monitored by means of a load cell and digital indicator.

Note: Any attachment that is not loaded centrally, as through the centerline of the ram, is considered to be "offset". When extension tubes and/or offset attachments are used, the rated capacity is always reduced by 50% for each tube or offset attachment connected.

1. Pump may be used in horizontal and vertical position as illustrated on figure 2 below.

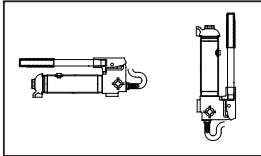

Figure 2 - Horizontal and Vertical position

2. Locate and close release valve by turning it clockwise until firmly closed. (Do not over tighten)
3. Operate by pumping handle. This will send fluid from the pump reservoir into the high pressure hose assembly and into the ram assembly.
4. Continue pumping until ram reaches desired position.

⚠ NEVER operate pump with release valve closed and disconnected from application. If operated in this condition, the hose and connections become pressurized. This increases burst hazard. Damage may occur to pump and its components.

5. To Release Pressure on work piece: Slowly, carefully turn the release valve counter-clockwise until ram retracts to desired position. Never turn release valve more than 1/2 full turn. The ram return system is spring loaded and the release valve system is metered, allowing controlled retraction of the ram.

MAINTENANCE

1. Inspect hoses and connections daily. Replace damaged components immediately with BVA Hydraulics Replacement Parts only.
2. Tighten connections as needed. Use pipe thread sealing compound when servicing connections.
3. Use only good quality hydraulic fluid. We recommend BVA FJZ01 or equivalent. **Never** use brake fluid, transmission fluid, turbine oil, motor oil, alcohol, glycerin etc. Use of other than good quality hydraulic oil will void warranty and damage the pump, hose, and application.

Adding Hydraulic Oil

1. With ram fully lowered, set pump unit in its normal, level position. Locate and remove oil filler screw.
2. Fill until oil is within 3/8" of the oil filler screw hole opening, re-install oil filler screw.

Changing Hydraulic Oil

For best performance and increased system life, replace the complete fluid supply at least once per year.

1. With ram fully lowered, remove the oil filler screw from the pump reservoir as above.
2. Lay the pump on its side and drain the fluid into a suitable container.

Note: Dispose of hydraulic fluid in accordance with local regulations.

3. Set pump in its level upright position.
4. Fill with good quality jack oil to within 3/8" of the oil filler screw hole opening. Reinstall oil filler screw.

Lubrication

A coating of light lubricating oil to pivot points and hinges will help to prevent rust and assure that pump assemblies move freely.

Cleaning

Periodically check the pump piston and ram for signs of rust or corrosion. Clean as needed and wipe with an oily cloth.

Note: Never use sandpaper or abrasive material on these surfaces!

Storage

When not in use, store with the pump piston and ram fully retracted.

How to remove faulty coupler:

If ram does not retract,:

1. Secure load by other means.
2. Depressurize pump and hose
3. Remove the ram from application.
4. Disconnect and replace with new coupler.

Important: Do not attempt to grasp ram with pliers or wrench without first wrapping the jaws of such tool with rags or similar padding.

How to bleed air from system:

1. Place pump at a higher elevation than the hose and ram as shown in figure 3 below.
2. Operate pump to fully extend and retract the ram 2 or 3 times. The objective is to force the air bubbles up hill and back to the pump reservoir.
3. To bleed the air from pump reservoir, simply open the oil filler screw. Re-install after bleeding.

TROUBLESHOOTING GUIDE

The following information is intended as an aid in determining if problem exists. Pump and ram should be repaired only by authorized BVA Service Center. For repair service, contact service center in your area.

Symptom	Possible Causes	Corrective Action
Erratic action	<ul style="list-style-type: none"> • Air in system or pump cavitation. • External leakage in ram. • Ram sticking or binding. 	<ul style="list-style-type: none"> • Vent the system (refer to figure 2). • Contact service center. • Contact service center.
Ram will not extend, or respond to pressurized fluid	<ul style="list-style-type: none"> • Overload condition. • Loose/Faulty couplers. • Oil level in pump is low. 	<ul style="list-style-type: none"> • Remedy overload condition. • Tighten/Replace couplers. • Fill and bleed the system.
Ram extend only partially	<ul style="list-style-type: none"> • Oil level in pump is low. • Overload condition. • Ram is sticking or binding. • Pump malfunction. 	<ul style="list-style-type: none"> • Fill and bleed the system. • Remedy overload condition. • Contact service center. • Contact service center.
Ram move slower than normal	<ul style="list-style-type: none"> • Loose connection or coupler. • Restricted hydraulic line or fitting. • Pump not working correctly. • Ram seals leaking. 	<ul style="list-style-type: none"> • Tighten connection or coupler. • Clean and replace if damaged. • Check pump's operating instructions. • Contact service center.
Ram responds to pressurized fluid, but system does not maintain pressure	<ul style="list-style-type: none"> • Overload condition. • Pump malfunctioning. • Ram seals leaking. 	<ul style="list-style-type: none"> • Remedy overload condition. • Contact service center. • Contact service center.
Oil leaking from ram	<ul style="list-style-type: none"> • Worn or damaged seals. 	<ul style="list-style-type: none"> • Contact service center.
Ram will not retract or retracts slower than normal	<ul style="list-style-type: none"> • Malfunctioning coupler, damaged application. • Pump reservoir overfilled. • Ram damage internally. 	<ul style="list-style-type: none"> • Secure load by other means. Depressurize pump and hoses, remove application and replace coupler. • Secure load by other means. Depressurize pump and hoses, remove application, then drain fluid to proper level. • Contact service center.
Poor performance	<ul style="list-style-type: none"> • Oil level in pump is low. • Air trapped in system. 	<ul style="list-style-type: none"> • Ensure proper oil level. • Vent the system (refer to figure 3).



Maintenance Kit Service Parts

MODEL: HFSS14

SFA Companies 10939 N. Pomona Ave. Kansas City, MO 64153
 Tel: 888-332-6419 * Fax: 816-448-2142
 E-mail: sales@bvahydraulics.com Website: www.bvahydraulics.com

Note: Not all components of the Hydraulic Spreader are replacement items, but are illustrated as a convenient reference of location and position in the assembly sequence.

Parts List

Item	Part Number	Description	Qty
1	N/A	Support Body	1
2	*	Dust-seal	1
3	H10-5-1804-208	Upper-bearing	1
4	N/A	Cylinder	1
5	644-1-0060-200	Bolt	1
6	H10-4-0202-209	Return spring assy.	1
7	N/A	Plunger	1
8	H10-5-1204-204	Bearing	1
9	*	Back-up ring	1
10	*	U-Cup	1
11	*	Special washer	1
12	*	Bolt	1
13	CH14F	Female coupler	1
14	CDC38	Dust cap assy.	1
15	H51-6-2102-105	Connector	1
16	H51-6-2002-101	Wedge	1
17	H51-6-2001-109	Jaw	2
18	641-1-0060-007	Bolt	6
19	H51-6-2005-107	Pin	4
20	H51-6-2006-109	Bolt	8
21	H51-6-2101-103	Handle	1
22	642-1-0060-05911	Bolt	1
23	649-1-0079-105	Bolt	2
24	H51-6-2007-101	Adapter	1
25	601-8-0006-001	Grease Nipple	1
26	CFSS-01	Safety Support Block	1
*	H10-3-9905-101	Repair kit	-

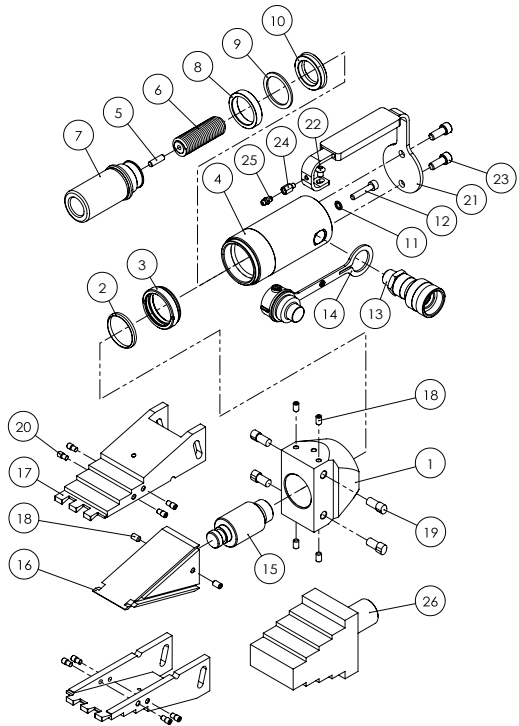

Note: To ensure safe and reliable performance, replace worn or damaged parts with BVA Hydraulics Authorized Replacement Parts only.

LIMITED LIFETIME WARRANTY

BVA Hydraulics®, represented in the United States by SFA Companies ["SFA"] warrants this product to be free from defects in material and workmanship for the life of the product as long as the original purchaser owns the product. The warranty is non-transferable and is subject to the terms, exclusions, and limitations described below:

- Damaged components, including but not limited to bent rams, dented or crushed ram walls, broken welds or couplers as well as worn out seals, o-rings and springs are the result of misuse and not covered by warranty and BVA Hydraulics will not provide any warranty credit for such damaged components.
- This warranty does not cover ordinary wear and tear, overloading, alterations (including repairs or attempted repairs not performed by BVA Hydraulics or one of its authorized personnel), improper fluid use, or use of the product in any manner for which the product was not intended or the use of which is not in accordance with the instructions or warnings provided with the product.
- In the unlikely event that a BVA Hydraulics product fails due to material defect in workmanship, you may contact SFA for disposition. In such cases, the customer's sole and exclusive remedy for any breach or alleged breach of warranty is limited to the repair or replacement of the defective product.
- Under no circumstances is BVA Hydraulics liable for any consequential or incidental damage or loss whatsoever.
- THIS WARRANTY IS LIMITED TO NEW PRODUCTS SOLD THROUGH AUTHORIZED DISTRIBUTORS AND OTHER CHANNELS DESIGNATED BY BVA HYDRAULICS. NO AGENT, EMPLOYEE OR OTHER REPRESENTATIVE OF BVA HYDRAULICS IS AUTHORIZED TO MODIFY THIS WARRANTY.
- THE FOREGOING IS EXCLUSIVE AND IS IN LIEU OF ALL OTHER EXPRESS AND IMPLIED WARRANTIES, INCLUDING BUT NOT LIMITED TO THE IMPLIED WARRANTIES OF MERCHANTABILITY AND FOR A FITNESS FOR A PARTICULAR PURPOSE.
- Components not manufactured by BVA Hydraulics including certain motor systems, gasoline engines, and other are not covered by this warranty and instead are covered by the manufacturer's separate manufacturer's warranty provided in the package.
- BVA Hydraulics' liability in all cases is limited to, and will not exceed the purchase price paid for the product.

SFA Companies
10939 N. Pomona Ave. Kansas City, MO 64153
Tel: 888-332-6419
E-mail: sales@bvahydraulics.com

